

# KE-434B

Electronic Lockstitch Pattern Tacker

# KE-435B

Electronic Lockstitch Pattern Tacker  
with Stepping Foot



## Specifications

	KE434B Electronic lockstitch pattern tacker	KE435B Electronic lockstitch pattern tacker with stepping foot
Stitch formation	Single needle lock stitch	
Max. sewing speed	2,500 rpm (Pitch: 3mm)	
Maximum pattern size	100 x 60 mm max.	
Feed mechanism	R-θ Intermittent feed mechanism (pulse-motor driven mechanism)	
Stitch length	0.1 – 10.0 mm	
No. of stitches	Variable	
Max. stitch number	20,000 stitches (including 10,000 stitches which can be added.)	
Work clamp lifter	Solenoid type or pneumatic type	Pneumatic type
Work clamp height	17 mm max. (for solenoid) 25 mm max. (for pneumatic) (Max. 17 mm for inner clamping device)	25 mm max.
Hook	Shuttle hook 2	
Wiper device	Standard equipment	
Thread trimmer device	Standard equipment	
Thread take-up device	Standard equipment	
Stepping foot lift amount		18 mm
Stepping foot stroke		0 mm, 3 – 8 mm
Safety device	Built-in stopping mechanism	
Data storage method	P-ROM (Any sewing pattern can be added using BAS-PC/300.)	
No. of user programs	16	
No. of cycle programs	4	
No. of stored data	Up to 100 patterns can be added. Total number of stitches of stored data which can be added is within 10,000.	
Motor	Three-phase 400W induction motor	
Weights	Machine head: 56 kg    Operation panel: 0.6 kg    Control box: 9 – 19 kg (depending on destination)	
Power source	Single-phase 110 V, 220 – 230 V, 240 V 3-phase 220 V, 380 V, 400 V Maximum electric power consumption; 600 VA	

## KE-434B-I□

The presser foot, feed plate and P-ROM can be ordered and manufactured to the customers' detailed specifications.

## KE-434 B-X□

1	Medium materials
2	Heavy materials

## KE-435 B

### [Main use]

\*Patterns up to a maximum size of 100 mm x 60 mm can be sewn.

For plain stitching of small articles, curtain darts, etc.

\*Two-stage work clamp, light work clamp and inner clamping device can be used (for pneumatic).

For attaching items, sewing labels, etc.

\*If you want to sew a pattern, you can create your original pattern using the BAS-PC/300.

Consult with your local Brother Sales Office for details.

## Optional parts Foot switch pedal mechanism (KE-434B)

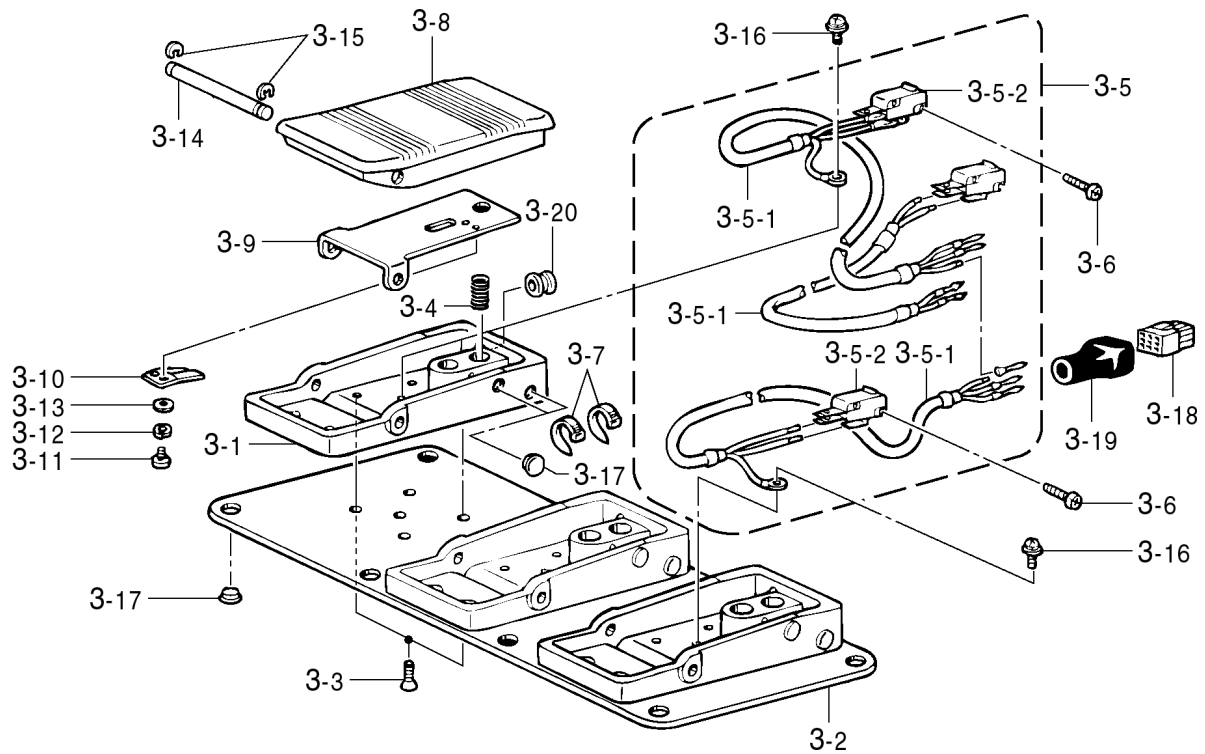

Ref. No.	Part name	Part code	Q'ty
	<b>&lt;For pneumatic type of 311E &amp; 311EL&gt;</b>		
3	3-pedal foot switch, 3	S44805-001	1
3-1	Foot pedal base	S38166-000	3
3-2	Treadle auxiliary plate	S42867-001	1
3-3	Screw, flat M4 × 6	004400-603	12
3-4	Spring, compression	S38170-001	3
3-5	3-pedal foot SW harness assy	S44806-000	1
3-5-1	3-pedal foot SW harness	S44807-000	1
3-5-2	Switch pin button, VX	S36260-000	3
3-6	Screw, pan M3 × 12	062301-205	6
3-7	Fastening band, 1.9 × 80	228475-000	10
3-8	Foot pedal	S38174-000	3
3-9	Pedal protection plate	S38175-001	3
3-10	Spring, plate	S38176-001	3
3-11	Screw, pan M3 × 4	002300-403	6
3-12	Washer, spring 2-3	028030-246	6
3-13	Washer, plain M3	025030-236	6
3-14	Foot pedal shaft	S38177-001	3
3-15	Retaining ring, E5	048050-346	6
3-16	Screw, pan (S/P washer) M4 × 6	052400-606	2
3-17	Rubber cap, 9.4	117936-001	14
3-18	Connector, 172169-1	S38180-000	1
3-19	Connector cap, 18 × 19	S38060-000	1
3-20	Rubber cap, NG79F	S38059-000	3

**Optional device  
Solenoid thread wiper (KE-434B)**

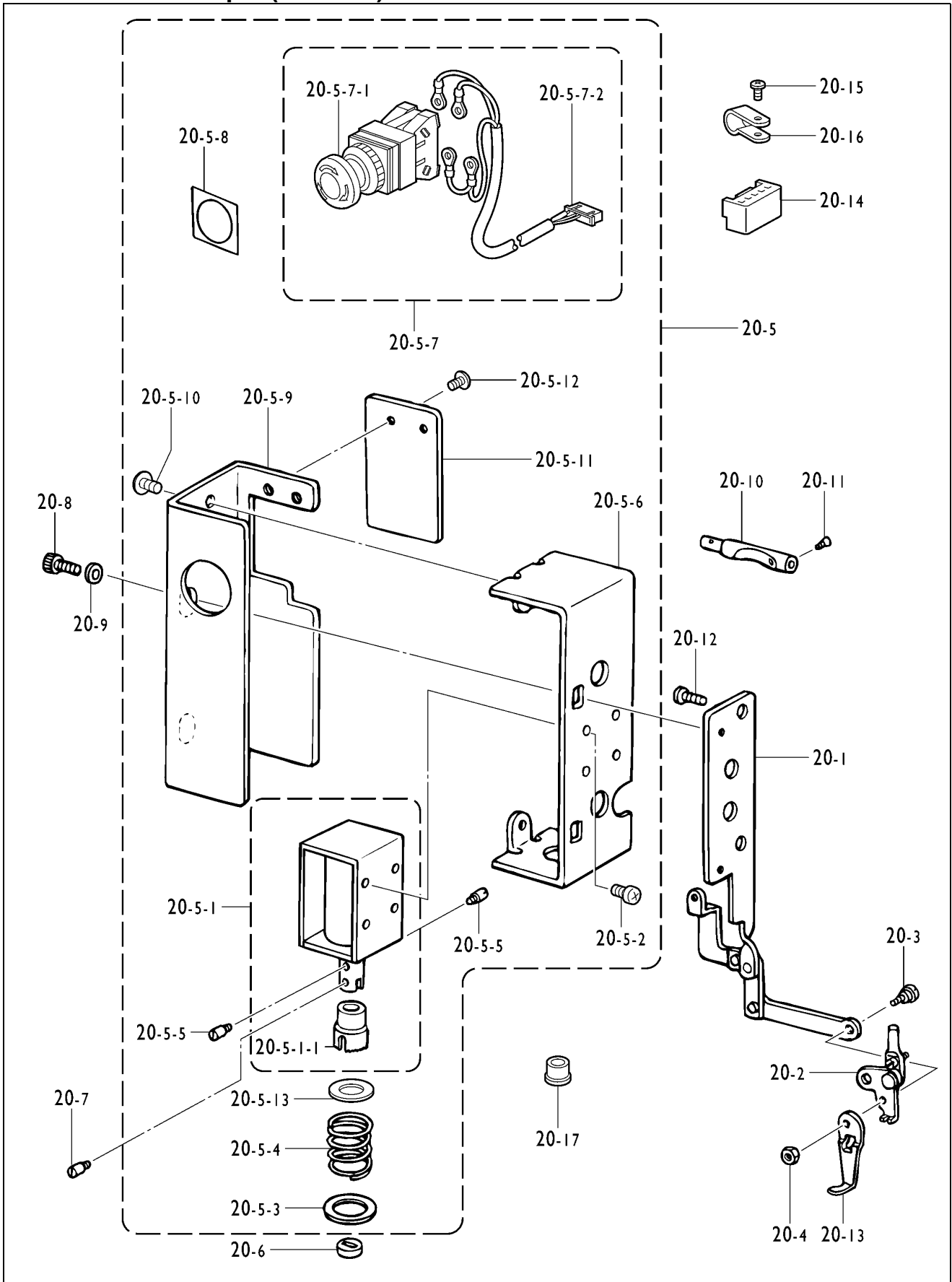





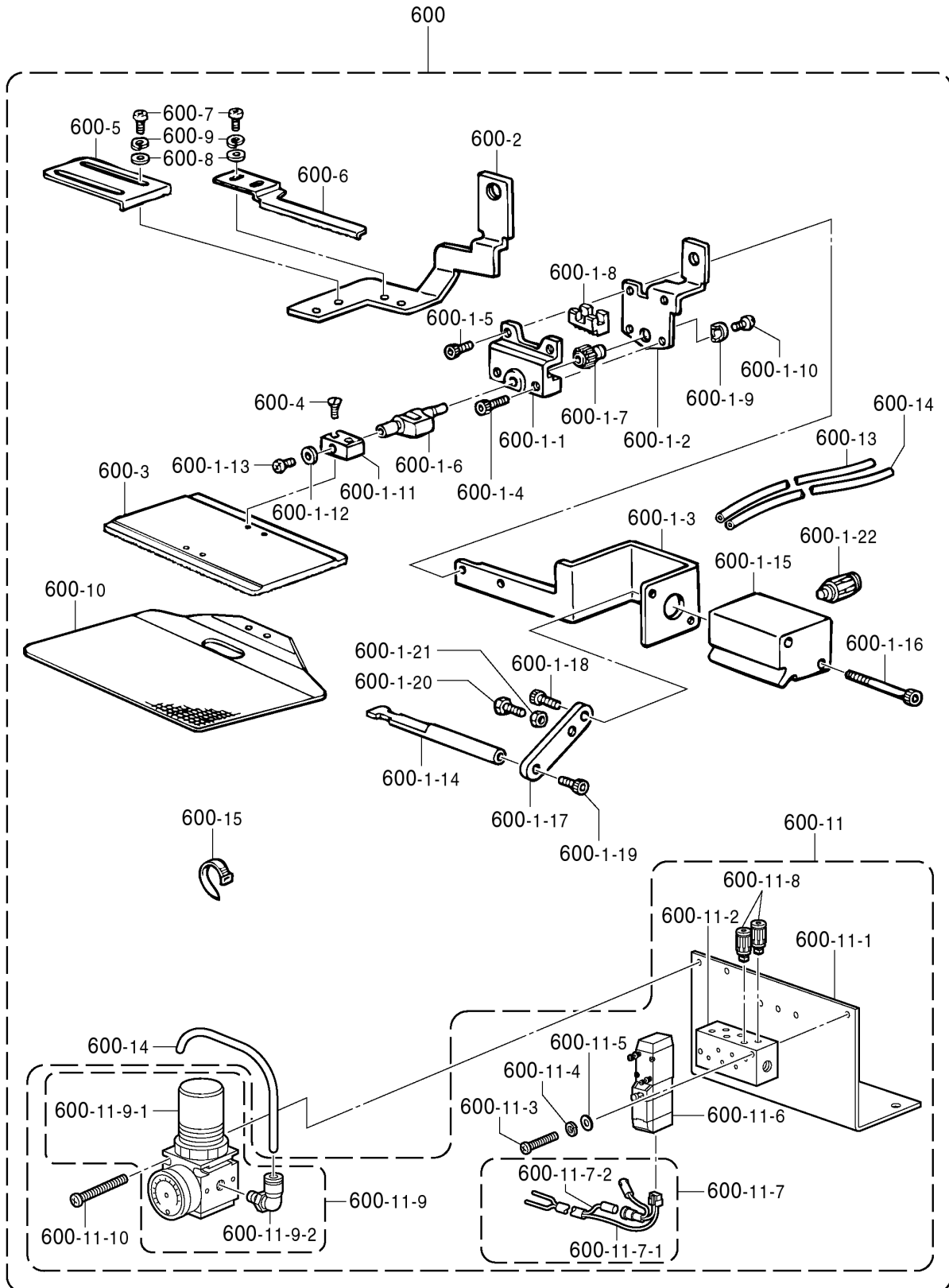







Ref. No.	Part name	Part code	Q'ty
20	Thread wiper solenoid assy	S49615-009	1
20-1	Connect rod assy, ; T-wiper	S41656-001	1
20-2	Thread wiper arm assy	S44600-001	1
20-3	Shoulder screw, SM3.57	153112-001	1
20-4	Nut, 2 SM3.57	021670-202	1
20-5	Solenoid box assy	S49616-009	1
20-5-1	Thread wiper solenoid assy	S49619-001	1
20-5-1-1	Plunger rubber	S41204-050	1
20-5-2	Screw, pan M3 x 6	062300-612	4
20-5-3	Washer, plain	S41205-001	1
20-5-4	Spring, t-wiper	S41206-001	1
20-5-5	Plunger pin	S25456-001	2
20-5-6	Setting plate, W-sol.	S42017-109	1
20-5-7	EM-lock switch harness assy	S49482-000	1
20-5-7-1	Switch, AVS311N	S32335-000	1
20-5-7-2	EM-switch harness	S49466-000	1
20-5-8	Spacer, 3 ;EM-switch	S37057-001	1
20-5-9	Solenoid cover, W	S42018-109	1
20-5-10	Screw, truss M4 x 6	008400-604	2
20-5-11	Solenoid cover lid, E	S37806-109	1
20-5-12	Screw, truss M4 x 6	008400-604	2
20-5-13	Washer, plain 13	115007-001	1
20-6	Spacer rubber	S41207-000	1
20-7	Plunger pin	S25456-001	1
20-8	Bolt, socket M4 x 6	018400-632	2
20-9	Washer	100645-003	2
20-10	Tension release rod, DW	S41657-001	1
20-11	Screw, flat M3.5 x 6	061350-616	1
20-12	Screw, pan SM4.37-40 x 8	062680-812	2
20-13	Thread wiper, A	156206-001	1
20-14	Connector, ;VHR-5N	S49947-000	1
20-15	Screw, bind SM3.57-40 x 6	060670-612	3
20-16	Cord holder, 7N	149287-000	3
20-17	Rubber cap, 15.5	104449-009	1

**Optional device**  
**Inner clamping device (KE-434B)**



Ref. No.	Part name	Part code	Q'ty
600	Inner clamp device set	S54771-001	1
600-1	Work clamp crank assy, 434E	S42007-001	1
600-1-1	Work clamp crank holder, A	S12634-009	1
600-1-2	Work clamp crank holder, B	S42008-001	1
600-1-3	Reverse cylinder base	S42019-001	1
600-1-4	Bolt, socket M3 × 12	018301-236	2
600-1-5	Bolt, socket M3 × 8	018300-836	2
600-1-6	Work clamp crank, LA	S05665-001	4
600-1-7	Reverse gear	154235-001	4
600-1-8	Reverse rack	154236-001	4
600-1-9	Washer	145087-001	4
600-1-10	Set screw, SM3.18	149831-101	4
600-1-11	Work clamp plate holder, L	154237-001	4
600-1-12	Washer	025350-132	4
600-1-13	Screw, SM3.57 – 40 × 5	100242-003	4
600-1-14	Reverse rod	S42020-001	4
600-1-15	Reverse cylinder	S12639-001	4
600-1-16	Bolt, socket M3 × 35	S12642-009	2
600-1-17	Reverse shaft joint	S42021-001	1
600-1-18	Bolt, socket M3 × 8	01830-836	1
600-1-19	Bolt, socket M3 × 8	018300-836	1
600-1-20	Bolt, M5 × 12	017501-216	1
600-1-21	Nut, 2M5	021500-216	1
600-1-22	Half union, ;Q4M5	S18415-101	2
600-2	Outer work clamp	S42009-101	1
600-3	Work clamp plate blank, A	154256-101	1
600-4	Screw, flat SM3.18	117291-002	2
600-5	Positioning plate, L	154252-001	1
600-6	Positioning plate, R	154253-001	1
600-7	Screw, pan SM3.57 – 40 - 5	062670-512	4
600-8	Washer, plain L3.5	025350-332	4
600-9	Washer, spring 2 – 3.5	028350-242	4
600-10	Feed plate blank, 434R1	S43459-001	1
600-11	Inner valve assy, 3	S44745-109	1
600-11-1	Setting plate, 4-5H, valve	S31570-309	1
600-11-2	Air manifold, 3	S44748-001	1
600-11-3	Screw, pan M3 × 25	062302-505	2
600-11-4	Washer, spring 2-3	028030-242	2
600-11-5	Washer, plain M3	025030-232	2
600-11-6	Solenoid valve	S43683-001	1
600-11-7	Valve harness assy, X1	S43696-100	1
600-11-7-1	Valve harness	S44746-100	1
600-11-7-2	Valve harness, 24V	S44750-100	1
600-11-8	Half union, ;Q4M5	S18415-101	2
600-11-9	Regulator assy	S45252-000	1
600-11-9-1	Regulator	S45253-00	1
600-11-9-2	Joint, 3109 – 4 - 10	S45254-000	2
600-11-10	Screw, pan M4 × 40	062404-005	2
600-12	Air tube, 4L = 300	S28741-000	1
600-13	Air tube, RV-3A L = 1600	S53118-001	1
600-14	Air tube, RV-3B L = 1600	S53118-002	1
600-15	Fastening bank, 1.9 × 80	228475-000	3



## Different parts list



Spec. Part name	Medium materials	Heavy materials	Extra heavy materials
Needle hole plate 	(φ2.2) S49980-001 FM	(φ2.6) S10212-101 E	◎
Bobbin case assy 	159610-301 A ◎	152690-401 B	◎
		S15902-401 LA	◎
Tension spring 	154339-101 A ◎	154340-101 B	◎
		S16074-101 LA	◎
Screw 		154341-001	◎
		S16492-101 LA	◎
Spring, anti-spin 	159612-001 A ◎	154342-001 B	◎
		S15667-001 LA	◎
Bobbin 	159613-051	154663-001 B	◎
		S44633-001 LAN	◎
Shuttle hook assy w/box 	152685-903 A ◎	152687-902 B	◎
	S15662-992 LA ◎	S15663-991 LB	◎
Shuttle race body 	152682-101 A ◎	152686-101 B	◎
Tension spring 	104525-001 ◎	107606-001 ◎	S06548-001 C
Thread take-up spring 	145519-001 ◎	144588-001 B	◎
Needle bar thread guide   A B	S41222-101 B ◎	152890-001 A ◎ 4350E / KE-435B S02438-001 A ○	S02439-001 B ◎

\*◎: Common with the LK3-B430E.

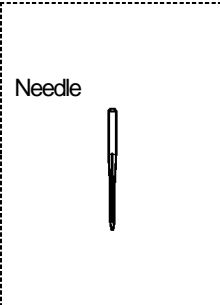
○: Common with the BAS-311E.

## Different parts list

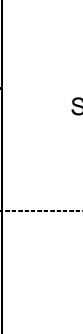
Spec. Part name	Medium materials	Heavy materials	Extra heavy materials
Needle assy 	107415-414 ◎	S37928-419 ◎	145646-425 ○
	Inner clamping device 145646-414 ◎		
Needle 	DP × 5 #14 107415-014 ◎	DP × 17 NY #19 S37928-019 ◎	DP × 17#25 145646-025 ○
	Inner clamping device DP × 17 #14 145646-014 ◎		

Spec. Part name	Medium materials	Heavy materials	Extra heavy materials	4350E 用 KE-435B
Work clamp blank 	434-1R ◎ S42030-001	434-2R ◎ S42032-001	154256-101 A ◎	434E SF-2R S46544-001
	434-1L ◎ S42031-001	434-2L ◎ S42033-001		434E SF-2L S46545-001
Feed plate blank 	434-1 ◎ S42034-001	434-2 ◎ S42035-001	434-R1 ◎ S43459-001	434E SF-2 S44942-001

\*◎: Common with the LK3-B430E.

○: Common with the BAS-311E.



# Gauge parts list

Optional gauges are listed in the following table.

Each work clamp pair is used in combination with the feed plate directly below them.

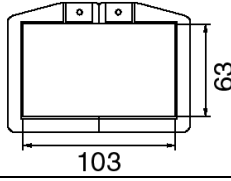
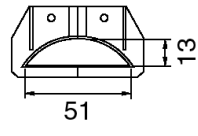
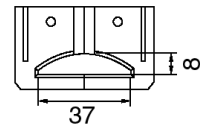
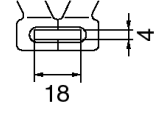
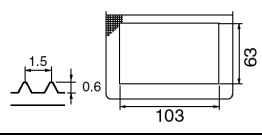
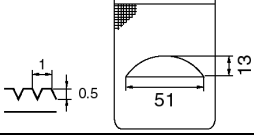
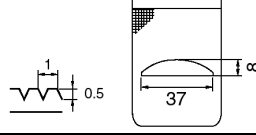
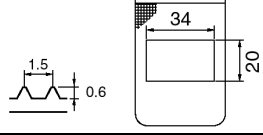
	1	2	3	4
R	153493-001	S23377-001 (519)	S27836-001 (895)	156085-001 (M)
L	153498-001	S23378-001 (519)	S27837-001 (895)	156086-001 (M)
Work clamp,				
Feed plate	153503-001 	S23379-001 (519) 	S27838-001 (895) 	156087-001 (M) 

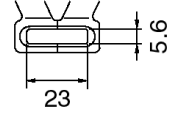
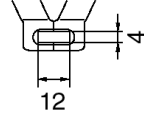
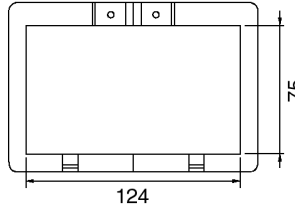
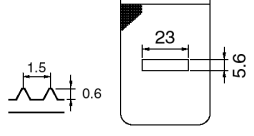
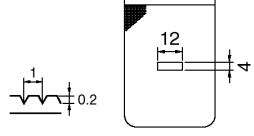
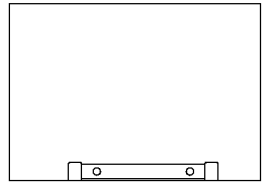
	5	6	7		
R	156082-001 (L)	156088-001 (S)	S44940-001 (434E SF)		
L	156083-001 (L)	156089-001 (S)	S44941-001 (434E SF)		
Work clamp,					
Feed plate	156084-001 (L) 	156090-001 (S) 	S43990-001 (A)   S43991-001 (B)   S43992-001 (C) Plastic work clamp blank  A: t = 0.5 B: t = 1.0 C: t = 2.0		

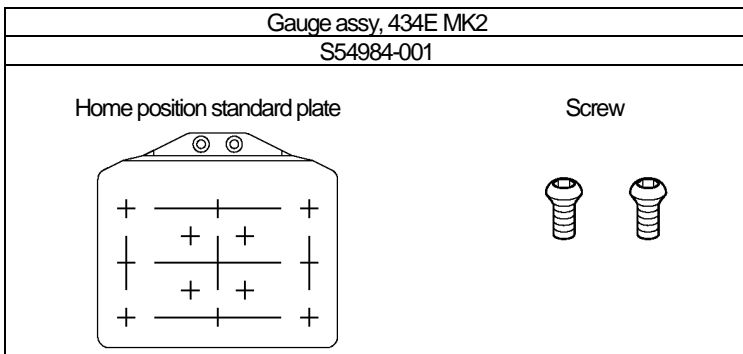

# Gauge parts list

Needle hole plate											
A	S10211-001	AF	S51449-001	BZ	S41013-001	D	S29997-001	E	S10212-101	ED	S30925-001
F	S10213-001	FD	S30926-001	FM	S49980-001	H	S30450-001	L	S25127-001	M	S34348-001
3	S40217-001										